



US008127645B1

(12) **United States Patent**  
**Mayfield**

(10) **Patent No.:** **US 8,127,645 B1**  
(45) **Date of Patent:** **Mar. 6, 2012**

(54) **METHOD AND APPARATUS FOR MACHINING PARTS OF PARTIAL REVOLUTION**

(75) Inventor: **Calvis L. Mayfield**, New Carlisle, IN (US)

(73) Assignee: **C M Grinding Incorporated**, South Bend, IN (US)

(\* ) Notice: Subject to any disclaimer, the term of this patent is extended or adjusted under 35 U.S.C. 154(b) by 360 days.

(21) Appl. No.: **12/575,348**

(22) Filed: **Oct. 7, 2009**

(51) **Int. Cl.**  
**B23C 9/00** (2006.01)  
**B23C 5/16** (2006.01)

(52) **U.S. Cl.** ..... **82/1.11**; 82/165

(58) **Field of Classification Search** ..... 82/1.11, 82/101, 102, 146, 147, 148, 162, 165  
See application file for complete search history.

(56) **References Cited**

**U.S. PATENT DOCUMENTS**

1,920,209 A 8/1933 Norton  
RE22,174 E 9/1942 Groene et al.

2,457,310 A \* 12/1948 Judelshon ..... 82/86  
3,044,367 A \* 7/1962 Thiel ..... 408/37  
3,490,336 A \* 1/1970 Staub ..... 82/1.3  
3,564,706 A \* 2/1971 Klingel ..... 29/564  
3,630,111 A 12/1971 Hartford et al.  
4,282,784 A \* 8/1981 Feller et al. .... 82/19

\* cited by examiner

*Primary Examiner* — Will Fridie, Jr.

(74) *Attorney, Agent, or Firm* — Botkin & Hall, LLP

(57) **ABSTRACT**

A machine and method for machining parts of partial revolution. The machine has a driving sheave rotatable about a first axis and a first driven sheave rotatable about a second axis fixed relative to the first axis. An eccentric link is rotatably connected to the first driven sheave at a pivotal connection that is spaced a predetermined distance from the second axis. A belt is wrapped around the driving sheave and the first driven sheave so that rotation of the driving sheave causes the first driven sheave to rotate. A second driven sheave is rotatable about a third axis fixed relative to the second axis. A second driven sheave contacts with the eccentric link. The eccentric link moves in a reciprocating motion when said first driven sheave is caused to rotate and causes reciprocating rotary motion in the second driven sheave, which is transferred to a part being machined.

**10 Claims, 5 Drawing Sheets**

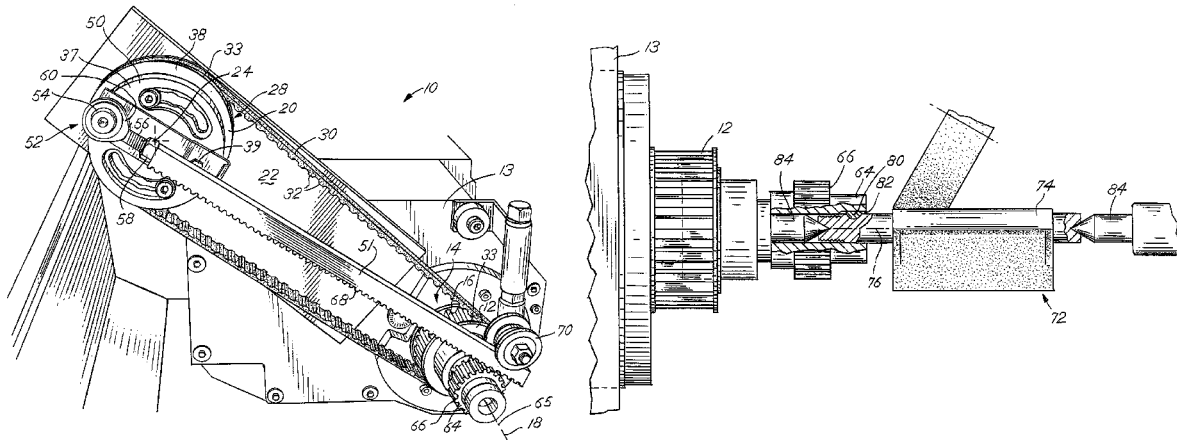

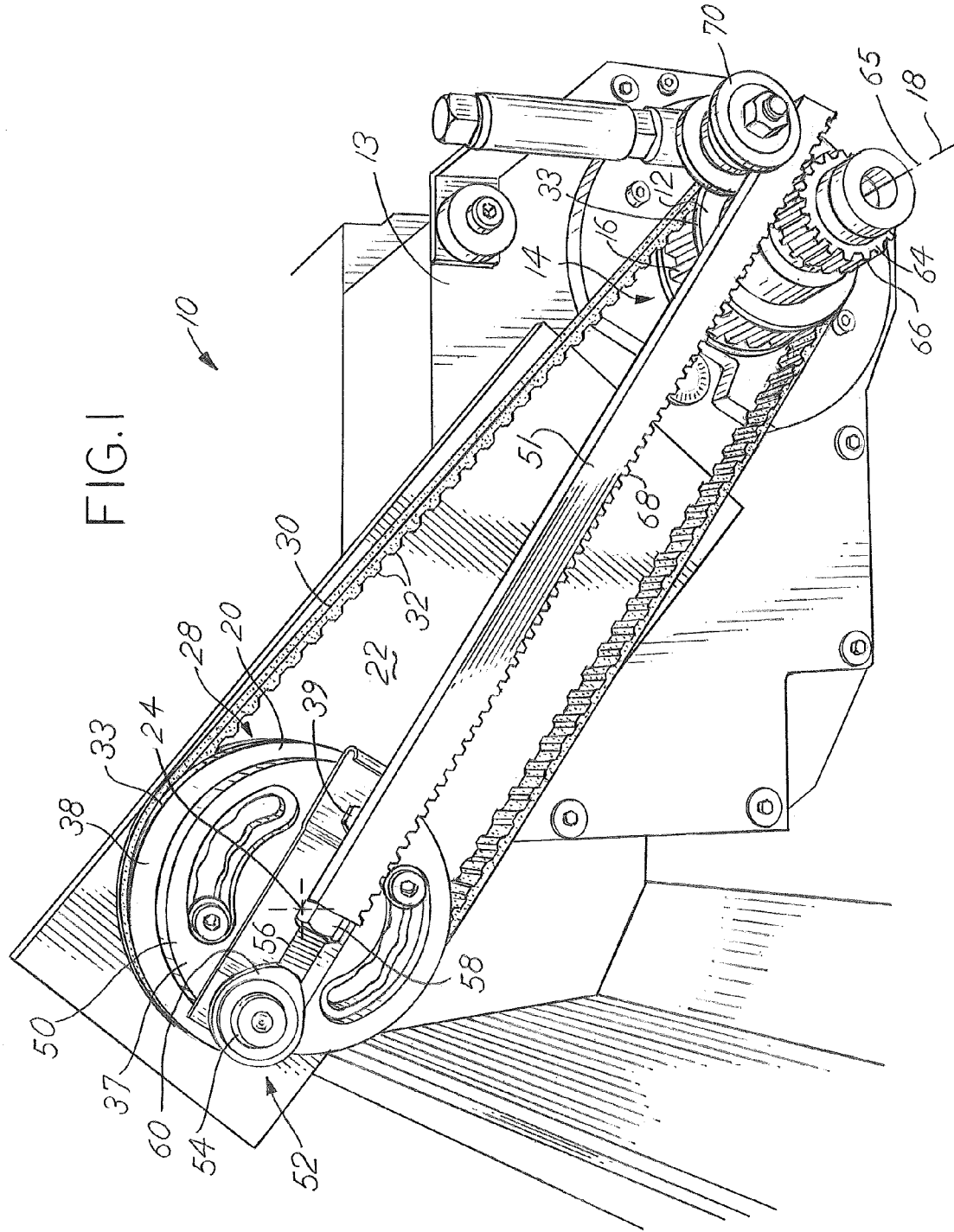

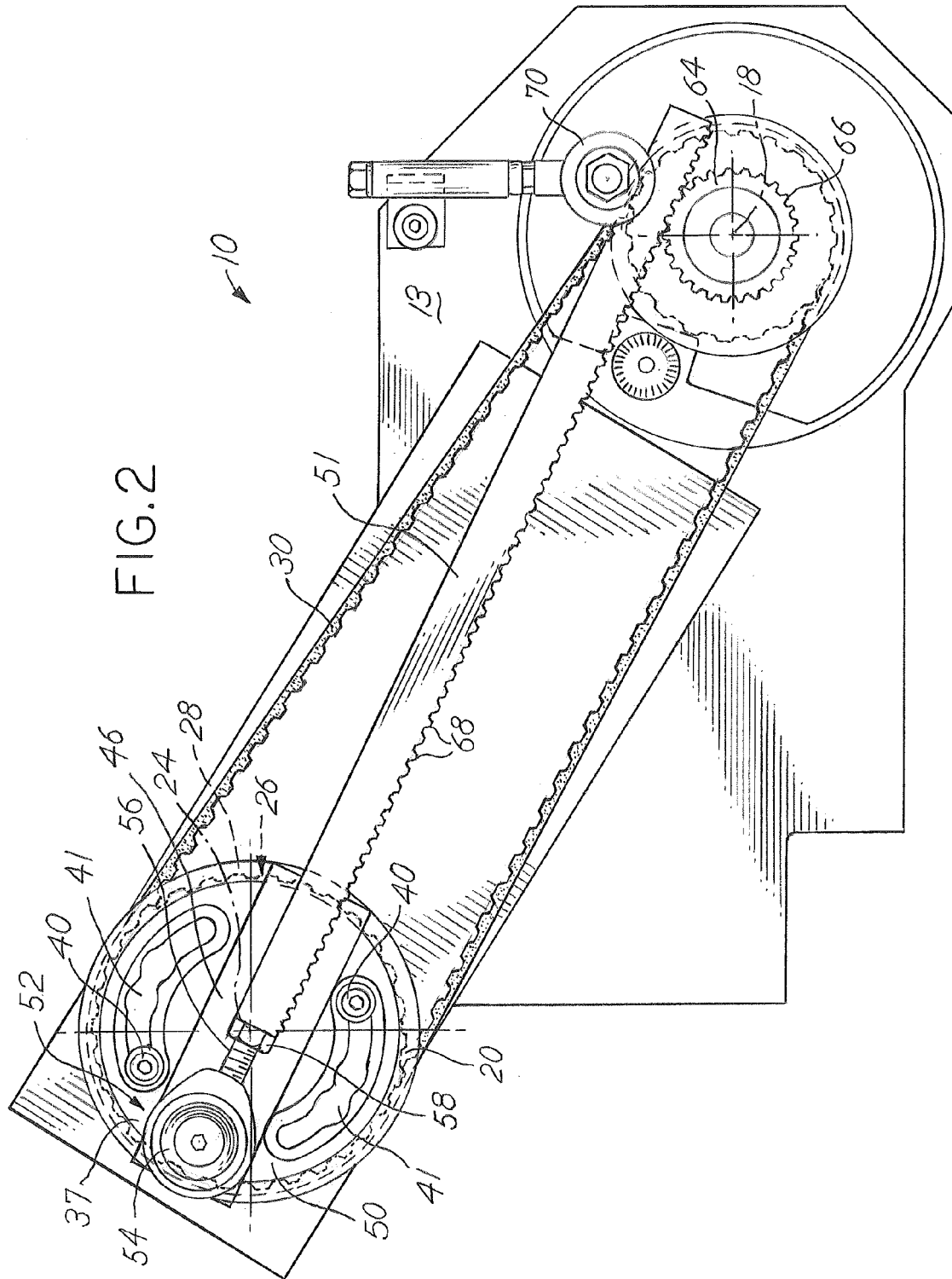

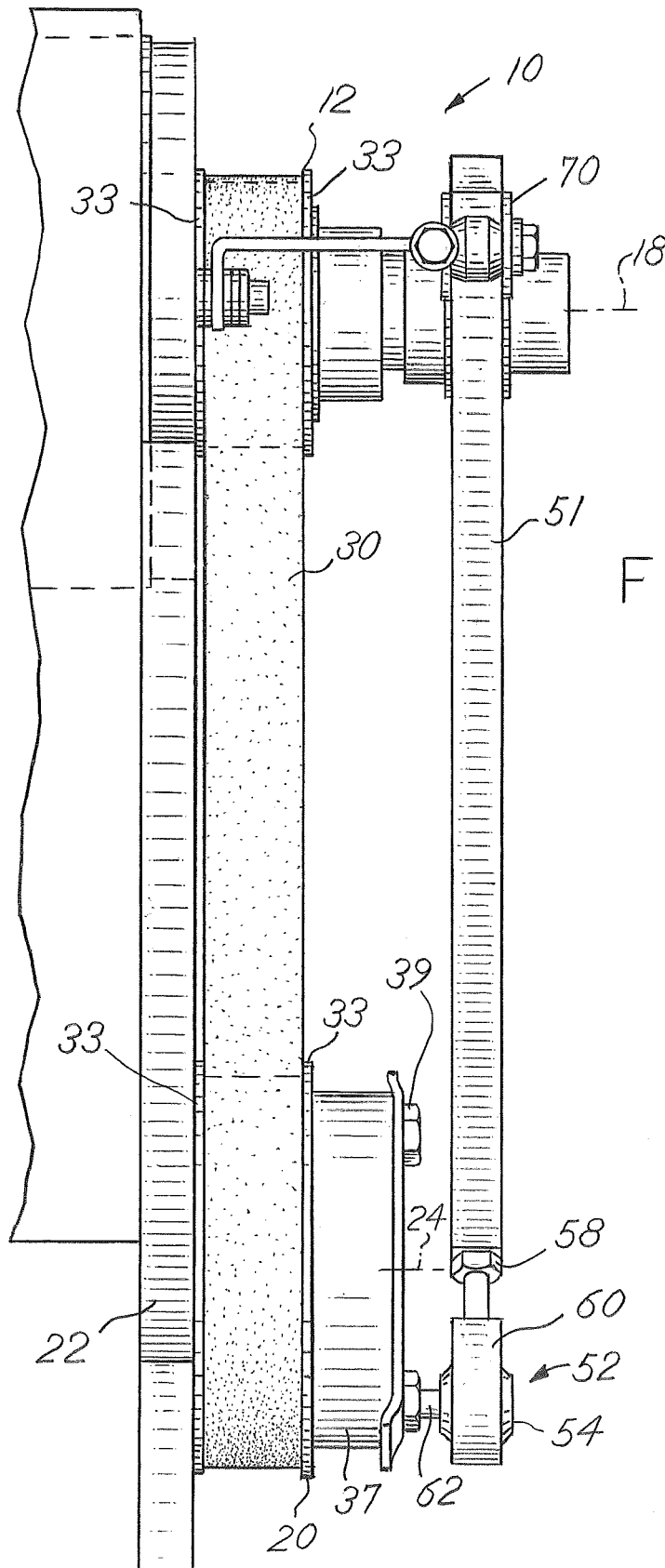

FIG. 3

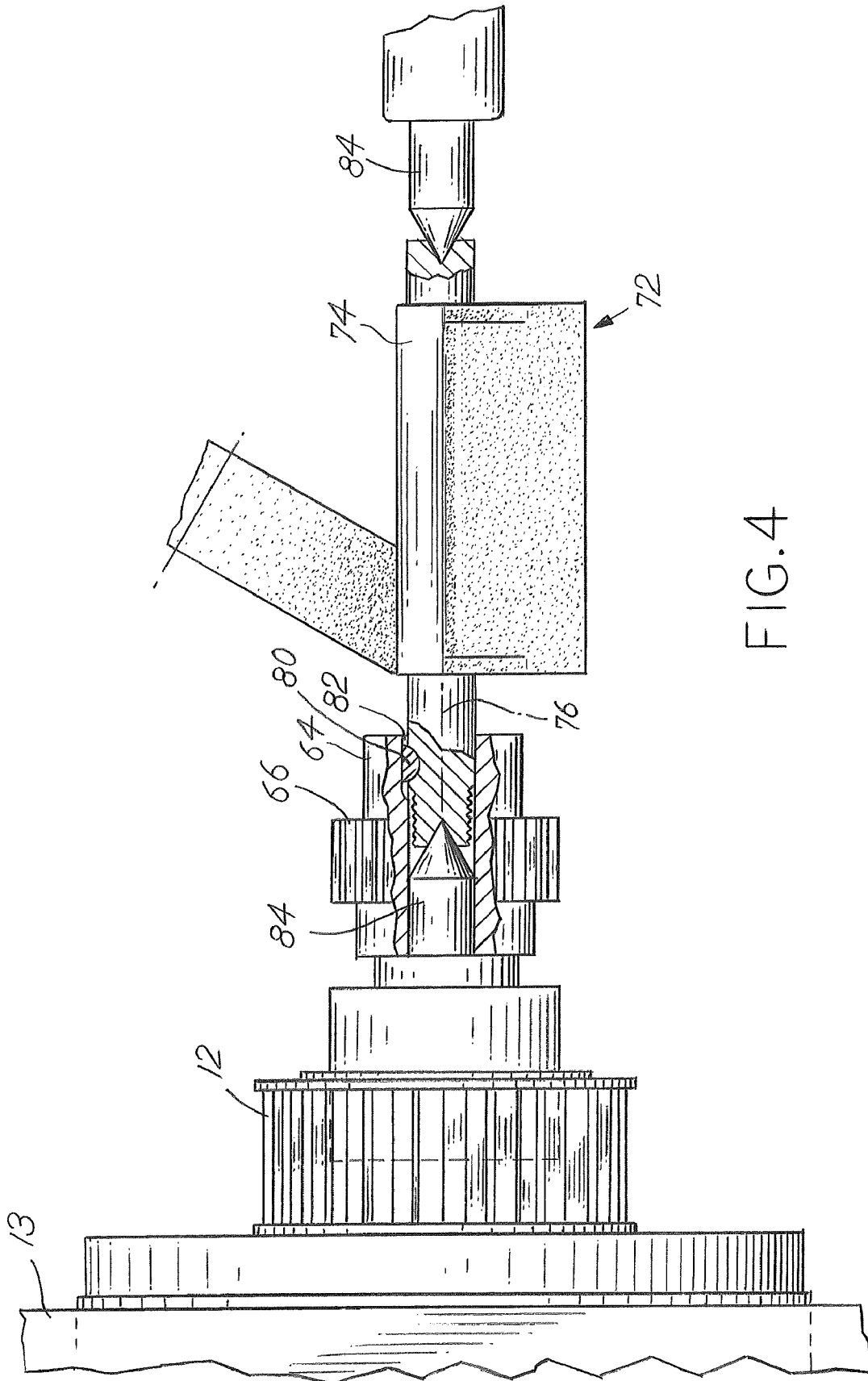
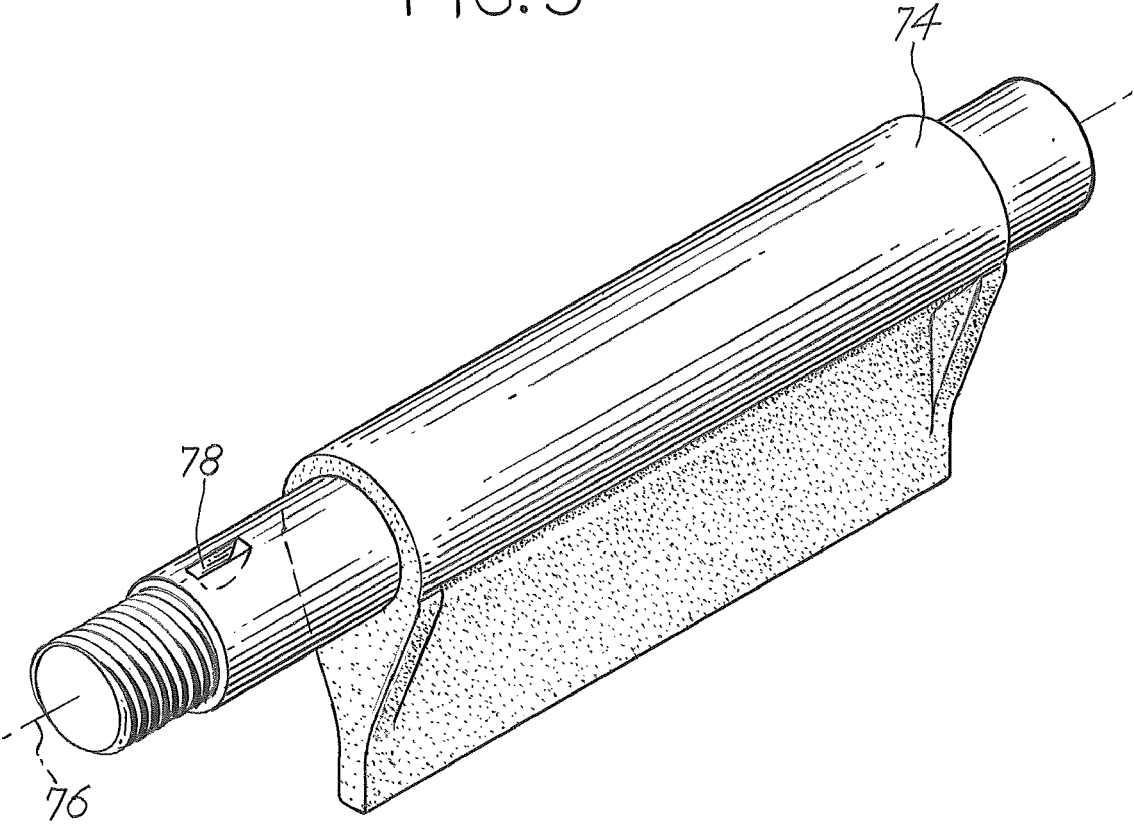

FIG. 5



1

## METHOD AND APPARATUS FOR MACHINING PARTS OF PARTIAL REVOLUTION

### BACKGROUND OF THE INVENTION

Machining parts of revolution is a well established operation that is usually accomplished using a rotating machine such as a lathe or a grinding machine. Doing so will result in a part having a symmetrical cross section when sectioned about the axis of rotation. However, not all parts are symmetrical, yet need to have a portion of their perimeter machined as revolved about an axis while the remainder of the part is a shape that could not be manufactured through simply revolving the part to remove material.

Machining only a portion of the perimeter where it is desired that the perimeter be concentric with an axis of the part would be useful, but would present challenges with regard to controlling dimensions of the part produced. A machine to perform that task would ideally provide for adjustment of the angular portion of the perimeter that would be machined concentric to the axis of rotation. When holding the part it would be useful to provide the capability of adjusting where the concentric portion would begin and end with respect to other features on the perimeter of the part. For production purposes, such a machine and related process would need to be reliably repeatable.

### SUMMARY OF THE INVENTION

The present invention is related to a machine for machining parts of partial revolution. The machine has a driving sheave rotatable about a first axis and a first driven sheave rotatable about a second axis fixed relative to the first axis. An eccentric link is rotatably connected to the first driven sheave at a pivotal connection that is spaced a predetermined distance from the second axis. A flexible band is wrapped around a portion of the driving sheave and the first driven sheave so that rotation of the driving sheave causes the first driven sheave to rotate. A second driven sheave is rotatable about a third axis fixed relative to the second axis. A second driven sheave is in contact with the eccentric link. The eccentric link moves in a reciprocating motion when said first driven sheave is caused to rotate and causes reciprocating rotary motion in the second driven sheave. The second driven sheave is adapted to be connected to a part to be machined so that the part rotates with the second driven sheave.

In another aspect of the invention the flexible band may be a belt. In the case where the belt has teeth, the driving sheave and the first driven sheave will also have teeth that interact with the teeth on the belt to prevent slippage.

In another aspect of the invention, the second driven sheave is a gear having teeth and the rack has teeth for interfacing with the gear.

In yet another aspect of the invention, the pivotal connection is connected to a slide plate and the slide plate is selectively slidable relative to the first driven sheave. The space between the pivotal connection and the axis of the first driven sheave may be changed by moving the slide plate.

### BRIEF DESCRIPTION OF THE DRAWINGS

FIG. 1 is a perspective view of the machine of the invention;

FIG. 2 is a front view of the machine shown in FIG. 1;

FIG. 3 is a top view of the machine shown in FIG. 1;

2

FIG. 4 is a top view of the machine shown in FIG. 1 also showing the part being machined and the grinding wheel machining the concentric portion of the part; and

FIG. 5 is a perspective view of the part shown in FIG. 4.

### DETAILED DESCRIPTION OF INVENTION

The machine **10** of this invention is shown in FIG. 1 and is a modified version of a typical grinding machine. The motor of the machine **10** rotates a driving sheave **12** that extends from the face **13** of the machine **10**. The driving sheave **12** has an outer surface **14** with teeth **16**. The driving sheave **12** rotates about a first axis **18**, which corresponds to its centerline.

A first driven sheave **20** is mounted to a mounting plate **22** that extends from the face **13** of the machine **10**. The first driven sheave **20** rotates about a second axis **24** that is fixed with respect to the first axis **18** of the driving sheave **12**. The first driven sheave **20** also has teeth **26** around its outer surface **28**. A belt **30** is wrapped around a portion of each of the outer surfaces **14**, **28** of the driving sheave **12** and the first driven sheave **20** so that when the driving sheave **12** rotates, the first driven sheave **20** also rotates. The belt **30** has teeth **32** that engage with the teeth **16**, **26** on the driving sheave **12** and the first driven sheave **20** so that no slippages occur between the belt **30** and sheaves **12**, **20**. Thus, the same proportional rotational relationship is maintained between the sheaves **12**, **20** at all times. The driving sheave **12** and driven sheave **20** each have collars **33** near their ends. The collars **33** maintain the belt in a centered position on the sheaves **12**, **20**.

The first driven sheave **20** has an adjustable cylinder portion **37** that is mounted on a front lateral surface **38** of the first driven sheave **20**. The cylinder **37** rotates with the first driven sheave **20** about the second axis **24**. The cylinder portion **37** is selectively rotatable relative to the first driven sheave **20**. Set screws **40** within slots **41** in the cylinder portion **37** are driven into the sheave **20** and when loosened, the cylinder portion **37** may be rotated relative to the sheave **20**. When the sheave **20** is moved into a desired position, the set screws **40** are tightened to lock the cylinder portion **37** relative to the first driven sheave **20**. A slide plate **46** is connected to a front face **50** of the cylinder portion **37** and selectively slidable relative to the first driven sheave **20**. The slide plate is attached to the cylinder portion **37** with bolts **39** in T-slots, which is a connection well known in the art of production machinery. FIG. 1 shows one of the bolts **39** holding the slide plate **46** in place. When the slide plate **46** is in the desired position, the bolts **39** are tightened to lock the slide plate **46** from sliding relative to the first driven sheave **20**.

An eccentric link, which in this case is a rack **51**, is pivotally connected to the slide plate **46** with a ball joint **52** driven into the slide plate **46**. The ball joint **52** has a ball end **54** and a threaded end **56**. The centerline of the threaded end shall be referred to as the axis of the ball joint **52** hereinafter. The ball end **54** of the ball joint **52** is spaced a predetermined distance from the second axis **24**, which corresponds to the center of the first driven sheave **20**. The amount of eccentricity or space from the second axis **24** may be changed by locking the slide plate **46** to a different position. The threaded end **56** of the ball joint **52** is threaded into the rack **51** and a jamb nut **58** is also located on the threaded end **56**. When the jamb nut **58** is tightened against the rack as shown in FIGS. 1 and 2, the ball joint **52** is rigidly connected to the rack **51** and cannot rotate about its axis relative to the rack **51**. When the jamb nut **58** is backed away from the rack **51**, the ball joint **52** may be rotated about the axis of the threaded end **56**. When the ball joint is turned clockwise as viewed from the ball joint **52** looking

toward the rack, the rack **51** will be brought closer to the ball end **54**. Rotating the ball joint **52** the opposite direction will move the rack farther from the ball end **54**. The ball joint may be rotated until the casing **60** of the ball joint **52** rests on the post **62**.

The rack **51** extends onto and contacts a second driven sheave which is a gear **64** having teeth **66** that engage teeth **68** on the rack **51**. The use of a gear **64**, as opposed to a smooth sheave, prevents slippage between the rack **51** and the gear **64**. The gear **64** is adjacent to the driving sheave **12** and rotates about a third axis **65** that is coaxial with the first axis **18** of the driving sheave. The gear **64** and driving sheave **12** rotate separately. An idler pulley **70** mounted to the front face **13** of the machine holds the rack into engagement with the gear **64**.

The gear **64** is adapted to be connected to a part **72**. FIG. 5 shows an example part **72** that has a portion **74** that is concentric with an axis **76** of the part **72** and is formed by revolving the part **72** about its axis **76**. The concentric portion **74** is typical of a part that would be machined on the device of this invention. The gear **64** is adapted to receive the part **72** so that the part **72** rotates with the gear **64**. The part **72** has a keyway **78** that receives a key **80**. The key **80** is also received in a keyway **82** in the gear, thus the gear **64** and the part **72** rotate together. The part **72** is held between live centers **84** so that it is rotatable about its axis **76** when the gear **64** rotates. The axis of the part **76** is coaxial with the third axis **65**.

When the motor within the machine **10** rotates the driving sheave **12**, the belt **30** will rotate the first driven sheave **20**. As the first driven sheave **20** rotates, this will cause reciprocating motion of the rack **51** as it pivots about the center of the ball end **54** of the ball joint **52**. The space between the second axis **24** and the center of the ball end **54** will determine the stroke length of the reciprocating motion. The reciprocating motion of the rack **51** will be transmitted to the gear **64** and the part **72**. Both the gear **64** and the part **72** will exhibit the same reciprocating rotary motion. The reciprocating rotary motion will correspond to a particular angle. Thus, the angle of reciprocating motion of the part **72** may be adjusted by moving the slide plate **46**. Therefore, the closer the center of the ball end **54** is to the second axis **24**, the smaller the angle the part **72** will reciprocate through.

As the part **72** rotates, a grinding wheel will traverse longitudinally along the machined concentric portion **74** to produce the concentric portion **74**. The desired angle of the concentric portion **74** that is machined may be adjusted by moving the slide plate **46** as described above. The farther the center of the ball end **54** is away from the second axis **24**, the larger the angle that will be machined into the concentric portion **74**. In the example part **72** shown, the concentric portion **74** is centered with respect to the keyway **78** of the part. In other words, the center of reciprocating rotary motion corresponds with the center of the concentric portion **74**.

In some instances it might be desirable to skew the machined concentric portion **74** with respect to the keyway **78**. Such an adjustment is made by loosening the set screws **40** in the cylinder portion **37** and rotating the cylinder portion relative to the first driven sheave **20**. The set screws **40** may then be tightened down and the center of reciprocation will be centered about a different line on the part **72**. This may be desirable if the keyway **78** of the part **72** is located in a different area of the part with respect to where the concentric portion is to be located. Moving the center of reciprocation may also be desirable when machining different types of parts. It should be noted that the angle of rotational reciprocation will not be affected by moving the cylinder portion **37** as described above.

Another way to adjust the center of reciprocation is to rotate the ball joint **52** about its axis. To do so, the jamb nut **58** is loosened, the rack **51** is lifted in order to disengage with the gear **64**, and the rack **51** is rotated one turn in the desired direction. This will provide fine adjustment for the center of reciprocation and may be done as a way of fine tuning the adjustments made by adjusting the cylinder portion **37** as described above. A finer adjustment is described above by rotating the ball joint **52** in either direction until the casing **60** of the ball joint **52** rests on the post **62**. Rotating the ball joint **52** will adjust the gear **64** by less than one tooth.

The invention is not limited to the description above, but may be modified within the scope of the following claims.

What is claimed is:

1. A machine for machining parts of partial revolution comprising:

a driving sheave rotatable about a first axis;  
a first driven sheave rotatable about a second axis fixed relative to said first axis;

an eccentric link rotatably connected to said first driven sheave at a pivotal connection being spaced a predetermined distance from said second axis;

a flexible band in contact with and wrapped around a portion of said driving sheave and said first driven sheave so that rotation of said driving sheave causes said first driven sheave to rotate; and

a second driven sheave rotatable about a third axis fixed relative to said second axis, said second driven sheave in contact with said eccentric link, said eccentric link moving in a reciprocating motion when said first driven sheave is caused to rotate, said eccentric link causing reciprocating rotational movement in said second driven sheave when said first driven sheave is rotated, said second sheave adapted for connecting to a part to be machined so that said part rotates with said second driven sheave.

2. A machine as claimed in claim 1, wherein said flexible band is a belt.

3. A machine as claimed in claim 2, wherein said driving sheave has an outer surface including teeth, and said first driven sheave has an outer surface including said teeth and said belt has teeth for meshing with said teeth on said driving sheave and said first driven sheave.

4. A machine as claimed in claim 3, wherein said eccentric link is a rack having teeth, and said second driven sheave is a gear having teeth for interfacing with said teeth on said rack.

5. A machine as claimed in claim 4, wherein said space between said pivotal connection and said second axis may be adjusted.

6. A machine as claimed in claim 5, wherein said gear and said driving sheave are coaxial.

7. A machine as claimed in claim 5, wherein pivotal connection is connected to a slide plate, said slide plate is selectively slidable relative to said first driven sheave, and said space between said pivotal connection and said second axis may be changed by moving said slide plate.

8. A machine as claimed in claim 7, wherein said first driven sheave includes an adjustable cylinder portion releasably mounted to a lateral surface, said cylinder portion selectively rotatable relative to said first driven sheave, said slide plate being connected to said cylinder portion.

9. A machine as claimed in claim 7, wherein said pivotal connection is a ball joint having a ball end and a threaded end, said threaded end having a jamb nut thereon and said threaded end threaded into said rack so that rotation of said ball joint about the axis of the threaded portion will move said rack relative to said ball end.



5

10. A method for machining a part of partial revolution including the steps of:  
providing a driving sheave that is rotated about a first axis;  
providing a driven sheave that is rotatable about a second axis that is fixed relative to said first axis;  
connecting an eccentric link to said first driven sheave at a pivotal connection spaced a predetermined distance from said second axis;  
wrapping a flexible band around a portion of said driving sheave and said first driven sheave so that rotation of said driving sheave causes said first driven sheave to rotate;  
and

6

connecting said eccentric link to a gear that is rotatable about a third axis fixed relative to said second axis, said eccentric link moving in a reciprocating motion when said first driven sheave is caused to rotate causing reciprocating rotational movement in said gear, said gear adapted for connecting to a part to be machined so that said part rotates with said gear.

\* \* \* \* \*